

## ORION-USC (UNIVERSAL SACK CLOSER)

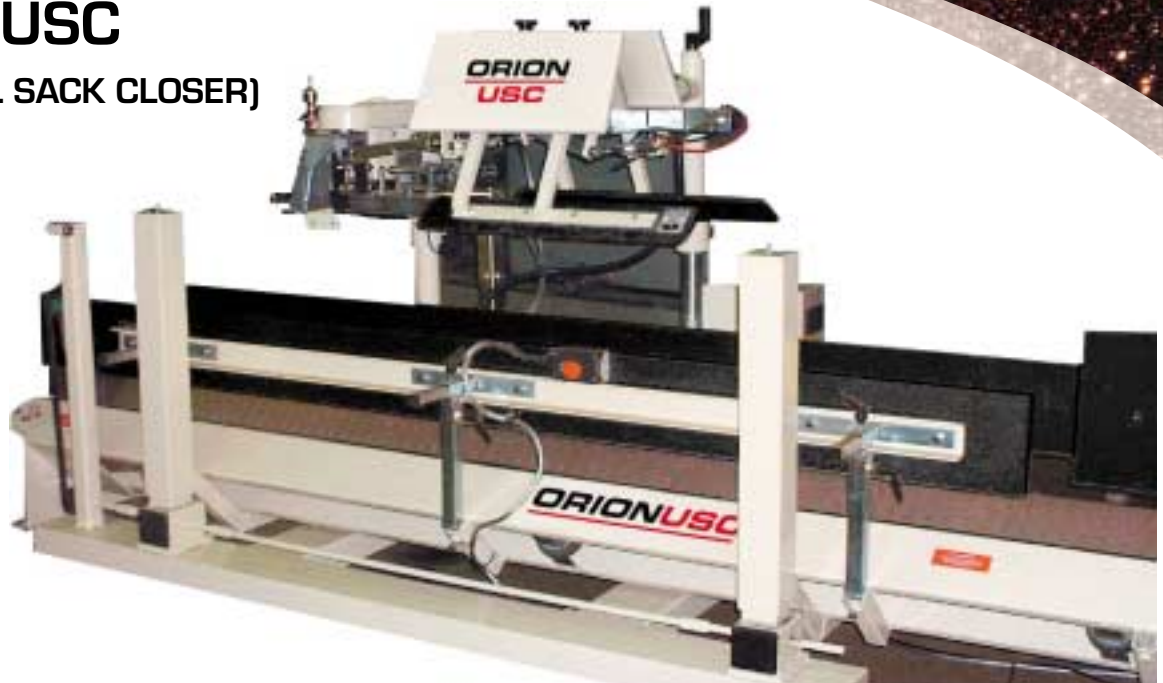

Whatever product you are packing, the **Orion-USC** is built smart and tough enough to cope.

Each component is assembled on single heavy-duty frame with locking castors.

Combined automation offers you effective high output and consistence performance; it has flexibility to be able to close most different types of sacks, by manual or automatic means.

You won't have to break the bank to be efficient. So break into the 21st Century and Experience Experience.

### Orion-USC



### FOR CLOSING

- Paper, Plastic, Jute, Hessian and Polypropylene Net sacks.
- Portions 5kg - 50kg
- Rugged mild steel construction
- Computer controlled operation with user friendly display
- Inform of service function
- Automatic or manual sack presentation
- Photocell controlled
- Adjustable height V track conveyer
- Abf 4000 presenter
- Ibiid1000 (belt in feed device)
- Adjustable food quality plastic guides
- Can be synchronized with any weighing/dosing system
- Economic machine with high running efficiency

### DIFFERENT MODELS

- Solok stitcher (Standard model USC)
- Newlong DS9C Sewing head (Heavy duty model)

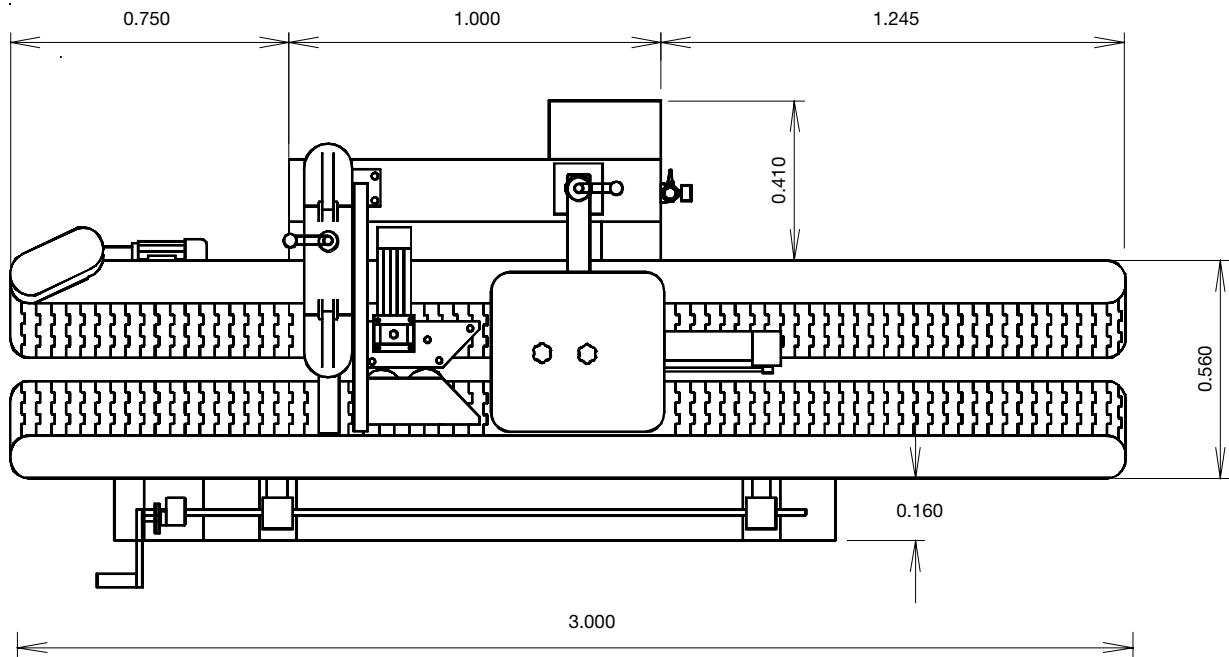

### CAPACITY

- 5kg 25 Pack/min
- 7.5kg 18 Pack/min
- 10kg 16 Pack/min
- 20kg 15 Pack/min
- 25kg 12 Pack/min

### OPTIONS

- Ink-Jet-Printer
- Synchronisation with any weighing system

### AIR REQUIREMENTS

Connection	1/4" Hose
Min. Pressure	6 bar / 80 psi
Air Consumption	5cfm

### ELECTRICAL REQUIREMENT

Total Consumption	1kw 380/440v / 50hz 1kw 220/240v / 50hz
Connection	3 phase + earth 1 phase + earth

### NOISE LEVEL

68 dB (A)

### TOTAL NET WEIGHT

550 kg

Your Local Dealer

## PACE MECHANICAL HANDLING LTD

Wensor Farm • Hop Pole • Deeping St Nicholas • Spalding • Lincs • PE11 3HL  
 Tel 0044 (0)1775 630900 Fax 0044 (0)1775 630899  
 Email sales@orionweigh.co.uk Web www.orionweigh.co.uk